

# MC-302V PG2

Supervised Vanishing Magnetic Contact Device



## Installation Instructions

### 1. INTRODUCTION

The MC-302V PG2 is a very thin PowerG magnetic contact device that is compatible with PowerMaster control panels. The device includes a built-in reed switch (that opens upon removal of a magnet placed near it). The MC-302V PG2 sends the alarm message to the control panel using PowerG 2-way communications protocol.

A periodic supervision or alarm message is transmitted automatically. The control panel is thus informed, at regular intervals, of the unit's active participation in the system.

The LED lights green/yellow/red, according to signal strength, upon first insertion of the battery and for the test period of 15 min.

LED does not light while a supervision message or event is being transmitted.

Operating power is obtained from an on-board 3 V Lithium battery. When the battery voltage is low, a "low battery" message is sent to the receiver.

The MC-302 V is available for 433 MHz, 868 MHz, and 915 MHz.

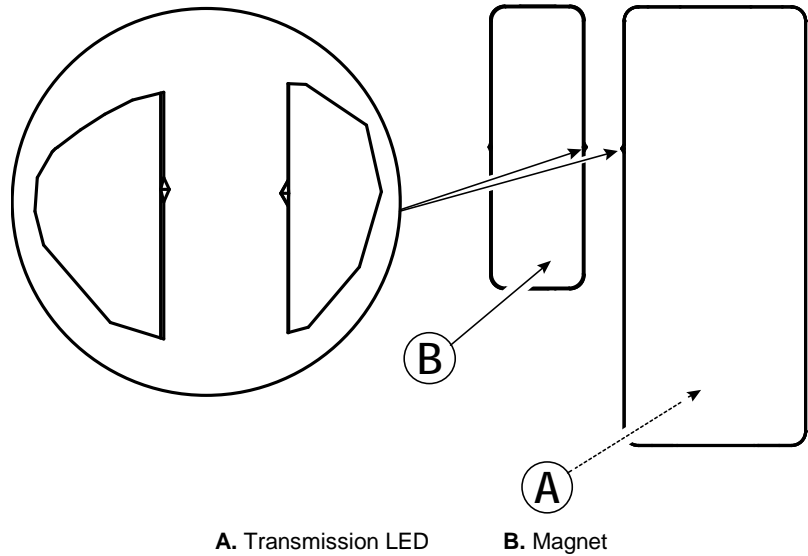
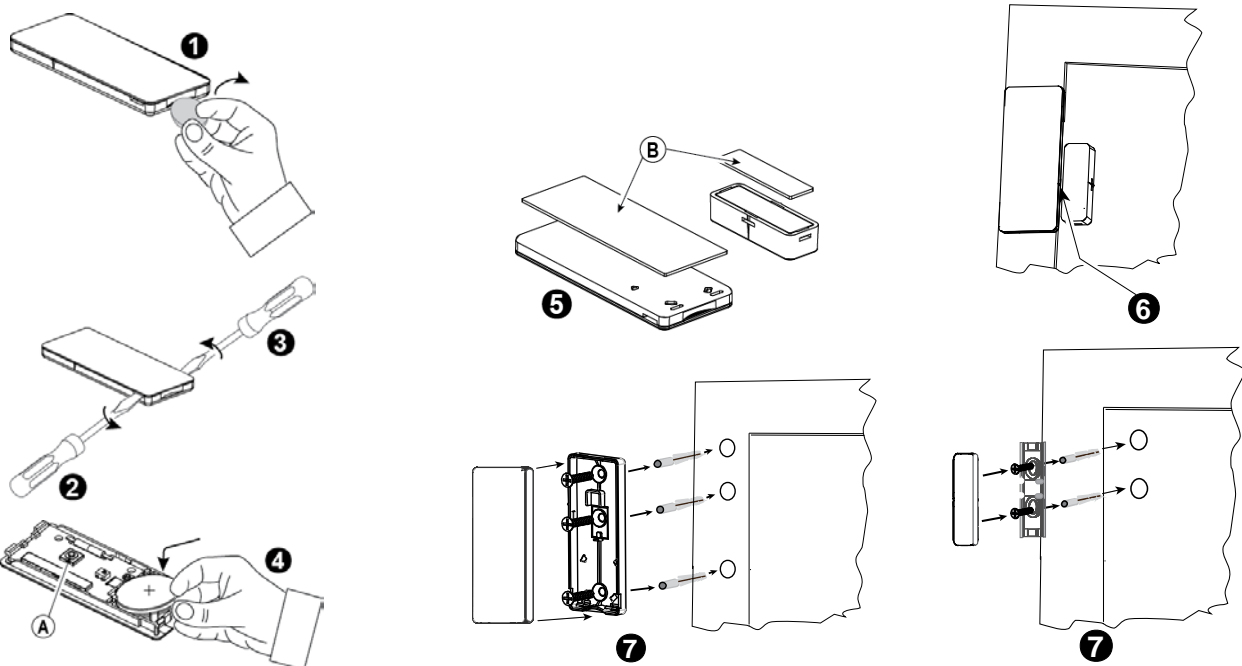

Figure 1: External View

### 2. INSTALLATION

**CAUTION:** This equipment shall be installed by Service Personnel in non-hazardous indoor locations only.

#### 2.1 Mounting



A. Enroll button B. Double-sided adhesive tape

Figure 2: Mounting

**Note:** The required battery is CR2032 Lithium 3V, manufactured by VARTA or another UL-recognized manufacturer, purchased from a Visonic-approved supplier.

**Note:** To comply with FCC and IC RF exposure compliance requirements, the device should be located at a distance of at least 20 cm from all persons during normal operation. The antennas used for this product must not be co-located or operated in conjunction with any

other antenna or transmitter.

1. Insert a "quarter" coin in the slot, as shown in the drawing, and flex to remove the cover  
- or, if a "quarter" coin is not available -
2. Insert a 4 mm flat screwdriver into the slot of the plastic cover, as shown in the drawing, and flex the slot to open that side of the plastic cover.
3. Insert the screwdriver into the slot on the other side of the plastic cover and repeat the procedure, and then remove the cover.
4. Insert the battery at an angle (see drawing) while observing battery polarity and then press down on the battery.  
**Caution!** Risk of explosion if battery is replaced by an incorrect type. Dispose of used batteries according to the manufacturer's instructions.
5. Peel away the release liners from the two strips of double-sided adhesive tape and attach to the device and magnet.
6. Align the device with the magnet according to the location marks and fasten the device and magnet to the mounting surface.  
**The transmitter should be mounted on the fixed surface and the magnet on the moving surface.**
7. **For installers of 433 or 868 MHz model:**  
Ensure that the heads of the tightened screws are flat perpendicular to the device surface.

## 2.2. Enrollment

Refer to the PowerMaster panel's Installer Guide and follow the procedure under the "02:ZONES/DEVICES" option of the Installer Menu. The following is a general description of the steps through the panel menu:

1. 02:ZONES/DEVICES
2. ADD NEW DEVICES > MODIFY DEVICES
3. ENROLL NOW or > ENTR ID:XXX-XXXX
4. Z06:Contact Sens > ID No. 104-XXXX
5. Z06:LOCATION > Z06:ZONE TYPE > Z06:SET CHIME > Z06:DEV SETTINGS

## 3. LOCAL DIAGNOSTICS TEST

Before testing, separate the base from the cover (see Figure 2).

- A. Put back the cover to return the tamper switch to its normal (undisturbed) position.
- B. Momentarily open the door or window and verify the red LED blinks, indicating detection.
- C. After 2 seconds one of the LED blinks 3 times.  
The following table indicates received signal strength indication.

LED response	Reception
Green LED blinks	Strong
Yellow LED blinks	Good
Red LED blinks	Poor
No blinks	No communication

**IMPORTANT!** Reliable reception must be assured. Therefore, "poor" signal strength is not acceptable. If you receive a "poor" signal from the device, re-locate it and re-test until a "good" or "strong" signal strength is received.

**Note:** For detailed Diagnostics Test instructions refer to the control panel Installer Guide.

## 4. MISCELLANEOUS COMMENTS

Visonic Ltd. wireless systems are very reliable and are tested to high standards. However, due to low transmitting power and limited range (required by FCC and other regulatory authorities), there are some limitations to be considered:

- A. Receivers may be blocked by radio signals occurring on or near their operating frequencies, regardless of the digital code used.
- B. A receiver responds only to one transmitted signal at a time.
- C. Wireless devices should be tested regularly to determine whether there are sources of interference and to protect against faults.

## 5. COMPLIANCE WITH STANDARDS



The MC-302V PG2 is designed to comply with the following:

**Europe:** EN 300220, EN 301489 EN 50130-4, EN 61000-6-3, EN 60950-1, EN 50131-1, EN 50131-2-6 and EN-50131-6 Type C.

Certified by Aplica Test and Certification

The MC-302V PG2 is compatible with the RTTE requirements - Directive 1999/5/EC of the European Parliament and of the Council of 9 March 1999.

**USA:** CFR 47 part 15 (FCC)

**Canada:** RSS 210

The Power G peripheral devices have two-way communication functionality, providing additional benefits as described in the technical brochure. This functionality has not been tested to comply with the respective technical requirements and should therefore be considered outside the scope of the product's certification.

**Security Grade**

Designed according to EN 50131-1, EN-50131-2-6 and EN-50131-6 Type C: this equipment can be applied in installed systems up to and including Security Grade 2.

**Environmental Class**

EN-50131-2-6 Class II

## FCC Compliance Statement

The digital circuitry of this device has been tested and found to comply with the limits for a Class B digital device, pursuant to Part 15 of the FCC Rules. These limits are designed to provide reasonable protection against harmful interference in residential installations. This equipment generates, uses, and can radiate radio frequency energy and, if not installed and used in accordance with the instructions, may cause harmful interference to radio and television reception. However, there is no guarantee that interference will not occur in a particular installation. If this device does cause such interference, which can be verified by turning the device off and on, the user is encouraged to eliminate the interference by one or more of the following measures:

- Re-orient or re-locate the receiving antenna.
- Increase the distance between the device and the receiver.
- Connect the device to an outlet on a circuit different from the one which supplies power to the receiver.
- Consult the dealer or an experienced radio/TV technician

**WARNING!** Changes or modifications to this unit not expressly approved by the party responsible for compliance could void the user's authority to operate the equipment.

This device complies with FCC Rules Part 15 and with Industry Canada licence-exempt RSS standard(s). Operation is subject to two conditions: (1) This device may not cause harmful interference, and (2) this device must accept any interference that may be received or that may cause undesired operation.

Le présent appareil est conforme aux CNR d'Industrie Canada applicables aux appareils radio exempts de licence. L'exploitation est autorisée aux deux conditions suivantes : (1) l'appareil ne doit pas produire de brouillage, et (2) l'utilisateur de l'appareil doit accepter tout brouillage radioélectrique subi, même si le brouillage est susceptible d'en compromettre le fonctionnement.

## Reed Switch Positions

Wood		Supports	Iron	
Opening	Closing	Direction	Opening	Closing
>14 mm	<12 mm	X	>12 mm	<9 mm
>22 mm	<20 mm	Y	>11 mm	<9 mm
>30 mm	<27 mm	Z	>12 mm	<9 mm

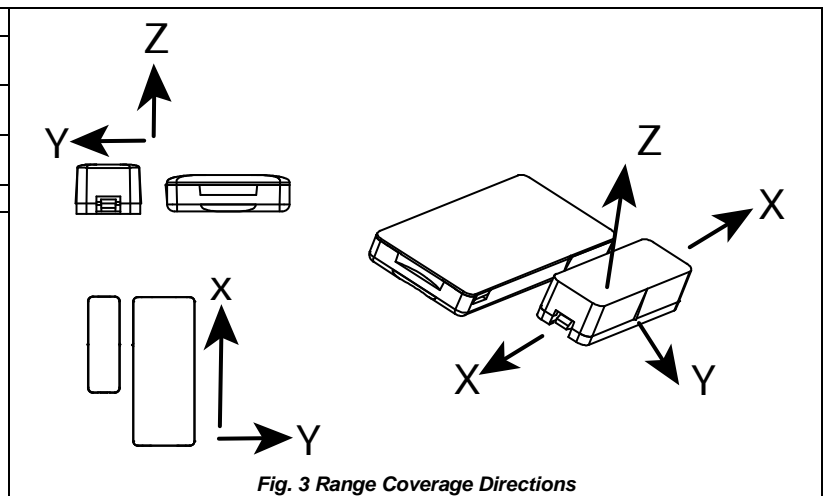

Fig. 3 Range Coverage Directions

## APPENDIX: SPECIFICATIONS

<b>Frequency Band (MHz)</b>	433, 868, 915 (in accordance with the prevailing frequency of your region)
<b>Modulation</b>	GFSK
<b>Antenna</b>	Built-in loaded inverted-F antenna
<b>Communication Protocol</b>	PowerG
<b>Supervision</b>	Signaling at 256 sec. intervals
<b>Battery type</b>	Varta 3V Lithium CR2032
<b>Battery Life Expectancy</b>	When used with V18 PowerMaster systems - Up to 5 years (with typical use) When used with V17 PowerMaster systems - Up to 3 years (with typical use)
<b>Low Battery Threshold</b>	2.1 V
<b>Operating Temperature</b>	-10°C to 55°C (14°F to 131°F)
<b>Storage Temperature</b>	-40°C to 85°C (-40°F to 185°F)
<b>Relative Humidity (RH)</b>	Up to 95% non-condensing
<b>Dimensions (LxWxD)</b>	433/868 MHz model: 62 x 25.4 x 7.6 mm (2.5 x 1 x 0.3 in.) 915 MHz model: 62 x 25.4 x 6.4 mm (2.5 x 1 x 0.26 in.)
<b>Weight (including battery)</b>	12g (0.42 oz)
<b>Color</b>	White or brown

## WARRANTY

Visonic Limited (the "Manufacturer") warrants this product only (the "Product") to the original purchaser only (the "Purchaser") against defective workmanship and materials under normal use of the Product for a period of twelve (12) months from the date of shipment by the Manufacturer.

This Warranty is absolutely conditional upon the Product having been properly installed, maintained and operated under conditions of normal use in accordance with the Manufacturers recommended installation and operation instructions. Products which have become defective for any other reason, according to the Manufacturers discretion, such as improper installation, failure to follow recommended installation and operational instructions, neglect, willful damage, misuse or vandalism, accidental damage, alteration or tampering, or repair by anyone other than the manufacturer, are not covered by this Warranty.

The Manufacturer does not represent that this Product may not be compromised and/or circumvented or that the Product will prevent any death and/or personal injury and/or damage to property resulting from burglary, robbery, fire or otherwise, or that the Product will in all cases provide adequate warning or protection. The Product, properly installed and maintained, only reduces the risk of such events without warning and it is not a guarantee of insurance that such events will not occur.

**THIS WARRANTY IS EXCLUSIVE AND EXPRESSLY IN LIEU OF ALL OTHER WARRANTIES, OBLIGATIONS OR LIABILITIES, WHETHER WRITTEN, ORAL, EXPRESS OR IMPLIED, INCLUDING ANY WARRANTY OF MERCHANTABILITY OR FITNESS FOR A PARTICULAR PURPOSE, OR OTHERWISE. IN NO CASE SHALL THE MANUFACTURER BE LIABLE TO ANYONE FOR ANY CONSEQUENTIAL OR INCIDENTAL DAMAGES FOR BREACH OF THIS WARRANTY OR ANY OTHER WARRANTIES WHATSOEVER, AS AFORESAID.**

**THE MANUFACTURER SHALL IN NO EVENT BE LIABLE FOR ANY SPECIAL, INDIRECT, INCIDENTAL, CONSEQUENTIAL OR PUNITIVE DAMAGES OR FOR LOSS, DAMAGE, OR EXPENSE, INCLUDING LOSS OF USE, PROFITS, REVENUE, OR GOODWILL, DIRECTLY OR INDIRECTLY ARISING FROM PURCHASER'S USE OR INABILITY TO USE THE PRODUCT, OR FOR LOSS OR DESTRUCTION OF OTHER PROPERTY OR FROM ANY OTHER CAUSE, EVEN IF MANUFACTURER HAS BEEN ADVISED OF THE POSSIBILITY OF SUCH DAMAGE.**

**THE MANUFACTURER SHALL HAVE NO LIABILITY FOR ANY DEATH, PERSONAL AND/OR BODILY INJURY AND/OR DAMAGE TO PROPERTY OR OTHER LOSS WHETHER DIRECT, INDIRECT, INCIDENTAL, CONSEQUENTIAL OR OTHERWISE, BASED ON A CLAIM THAT THE PRODUCT FAILED TO FUNCTION.**

However, if the Manufacturer is held liable, whether directly or indirectly, for any loss or damage arising under this limited warranty, **THE MANUFACTURER'S MAXIMUM LIABILITY (IF ANY) SHALL NOT IN ANY CASE EXCEED THE PURCHASE PRICE OF THE PRODUCT**, which shall be fixed as liquidated damages and not as a penalty, and shall be the complete and exclusive remedy against the Manufacturer.

When accepting the delivery of the Product, the Purchaser agrees to the said conditions of sale and warranty and he recognizes having been informed of.

Some jurisdictions do not allow the exclusion or limitation of incidental or consequential damages, so these limitations may not apply under certain circumstances.

The Manufacturer shall be under no liability whatsoever arising out of the corruption and/or malfunctioning of any telecommunication or electronic equipment or any programs.

The Manufacturers obligations under this Warranty are limited solely to repair and/or replace at the Manufacturer's discretion any Product or part thereof that may prove defective. Any repair and/or replacement shall not extend the original Warranty period. The Manufacturer shall not be responsible for dismantling and/or reinstallation costs. To exercise this Warranty the Product must be returned to the Manufacturer freight pre-paid and insured. All freight and insurance costs are the responsibility of the Purchaser and are not included in this Warranty.

This warranty shall not be modified, varied or extended, and the Manufacturer does not authorize any person to act on its behalf in the modification, variation or extension of this warranty. This warranty shall apply to the Product only. All products, accessories or attachments of others used in conjunction with the Product, including batteries, shall be covered solely by their own warranty, if any. The Manufacturer shall not be liable for any damage or loss whatsoever, whether directly, indirectly, incidentally, consequentially or otherwise, caused by the malfunction of the Product due to products, accessories, or attachments of others, including batteries, used in conjunction with the Products. This Warranty is exclusive to the original Purchaser and is not assignable.

This Warranty is in addition to and does not affect your legal rights. Any provision in this warranty which is contrary to the Law in the state or country where the Product is supplied shall not apply.

**Warning:** The user must follow the Manufacturer's installation and operational instructions including testing the Product and its whole system at least once a week and to take all necessary precautions for his/her safety and the protection of his/her property.

1/08



### W.E.E.E. Product Recycling Declaration

For information regarding the recycling of this product you must contact the company from which you originally purchased it. If you are discarding this product and not returning it for repair then you must ensure that it is returned as identified by your supplier. **This product is not to be thrown away with everyday waste.**  
Directive 2002/96/EC Waste Electrical and Electronic Equipment.



# Visonic

EMAIL: [info@visonic.com](mailto:info@visonic.com)

INTERNET: [www.visonic.com](http://www.visonic.com)

©VISONIC LTD. 2014 MC-302V (ROW) D-304535 (REV. 6,12/15)



D-304535