

# TOWER CAM PG2

## PowerG, Outdoor Mirror PIR Motion Detector with Anti-masking and Built-In Camera



# Installation Instructions

## 1. INTRODUCTION

The TOWER CAM PG2 is a 2-way, wireless outdoor digital mirror PIR detector with built-in camera. Activated upon PIR detection or upon demand, the TOWER CAM PG2 sends clear images to the Monitoring Station for alarm image verification.

**The PIR motion detector's features are as follows:**

- Operates with PowerMaster control panels (version 18 and higher)
- Patented 8 independent quad PIR detectors (Octa-QUAD™) operating in true Quad configuration (patented) with true motion recognition (TMR) processing for each of the 8 PIR detectors.
- Advanced Obsidian Black Mirror™ optics (patent pending).
- Optimum performance even in poor weather conditions such as snow, rain, dust, wind and direct sunlight
- Tamper protection prevents opening and removal from wall
- PowerG two-way Frequency Hopping Spread Spectrum [FHSS-TDMA technology](#) - provides robustness and reliability
- Built-in link quality indicators enable installer to check signal quality without physically approaching the control panel.
- Robust housing with recessed window.
- Smart anti masking distinguishes between masking spray and rain.
- Alarm LED is visible in sunlight.
- Automatic termination of walk-test after 15 minutes.
- Microprocessor-controlled temperature compensation.
- Immunity to pets weighing up to 18 Kg (40lb) – see Table 1
- Built-in swivel bracket

**The camera's features are as follows:**

- Up to 10 cameras can be enrolled
- Images multiplexed from all enrolled cameras
- Color and black & white images
- Auto-setup
- Camera tuning by simple walk-test
- Day and night CMOS camera, with near IR illumination. This allows taking pictures in full darkness without letting the intruder know.
- Instant capture: guarantees capture of fast moving intruder.
- Optional AC power
- An event records 2 images per second. 10-15 images total

**Notes:**

1. For UL/ULC installation, the camera feature is not to be enabled in UL listed product.
2. Pet immunity is not evaluated by UL/ULC.

## 2. INSTALLATION

### 2.1. Installation

- A. Bracket installation (see [Figure 2](#)). Fix the bracket firmly on a stable wall or pillar. The orientation of the fixed bracket must be as parallel as possible to the surveyed ground surface.
- B. Adjust the detector's horizontal and vertical angles (see [Figure 3](#)), according to the surveyed ground surface. Set the vertical angle position depending on the mounting height and coverage distance that you require. See Figure 3 A and Table 1 for details. The information refers to a relatively flat surveyed area. Verify the correct installation by using the walk test method.
- C. Fasten the detector to the bracket (see Figure 2 step 4).

**Table 1 - Vertical Adjustment Reference**

Mounting Height	Coverage Distance					
	2m / 6.7ft	4m / 13ft	6m / 20ft	8m / 26ft	10m / 33 ft	12m / 39 ft
3.0m / 10 ft	-	1	2	2	3	3
2.5m / 8 ft	1	1	2	3	4	4
2.0m / 7 ft	1	2	3	4	5	5
1.5m / 5 ft	2	3	4	5	5	-

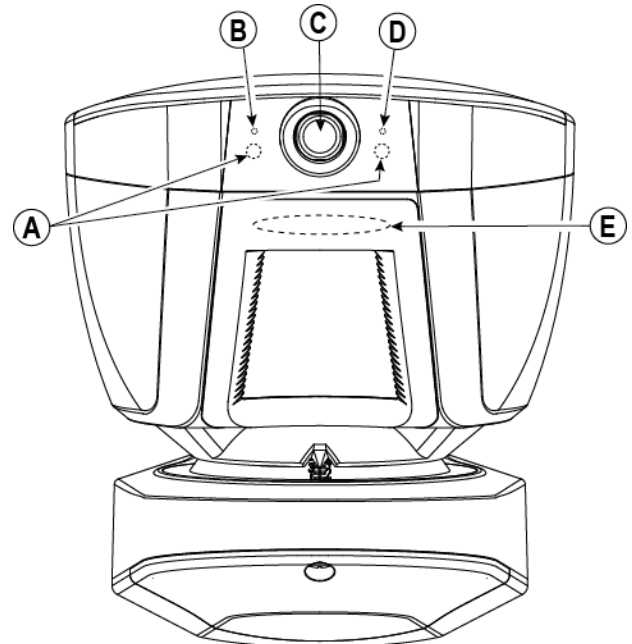



- A. IR LEDs
- B. Indication LED
- C. Camera
- D. External power LED
- E. Alarm LED

**Figure 1. External View**

**Notes:**

1. For UL/ULC listed installations see table 1 to set the correct angle when mounting at a height of 2.4 m (8ft).
2. For UL/ULC listed installations the maximum range of the detection is 10m (33ft).
3. For installation options to reduce the probability of false alarms from pets, see the grayed-in cells in Table 1.
4. For EN installations only and the distance ranges between 11 to 12 m (36 - 39ft), set the PIR sensitivity to "One region".

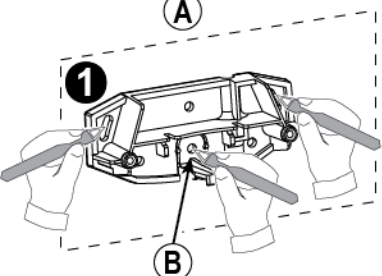
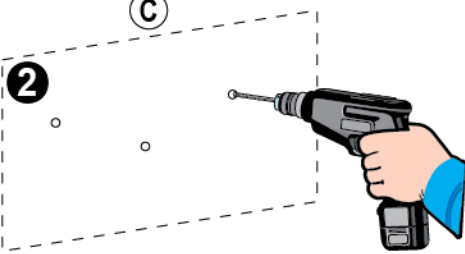
**Event counter: One region**

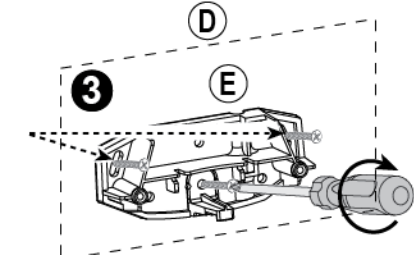
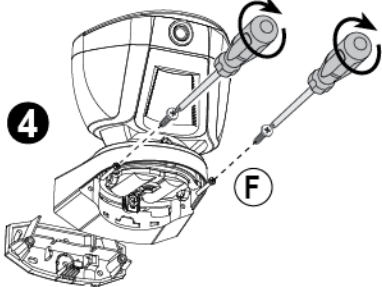
<p><b>Correct Installation</b></p> 	 <p><b>A</b></p>	 <p><b>C</b></p>
<p><b>Incorrect Installation</b></p> 	 <p><b>D</b></p>	 <p><b>F</b></p>
<p><b>A.</b> Mark drilling point                      <b>B.</b> Screw hole for wall tamper                      <b>C.</b> Drill</p> <p><b>D.</b> Fasten    <b>E.</b> Three long screws    <b>F.</b> Two short screws</p> <p><b>Note:</b> The 2 screw holes enable adjustment of the bracket on the wall, if needed, following the walk test.</p>		

**Figure 2 - Installation**

**HORIZONTAL ADJUSTMENT (-45° to +45°)**

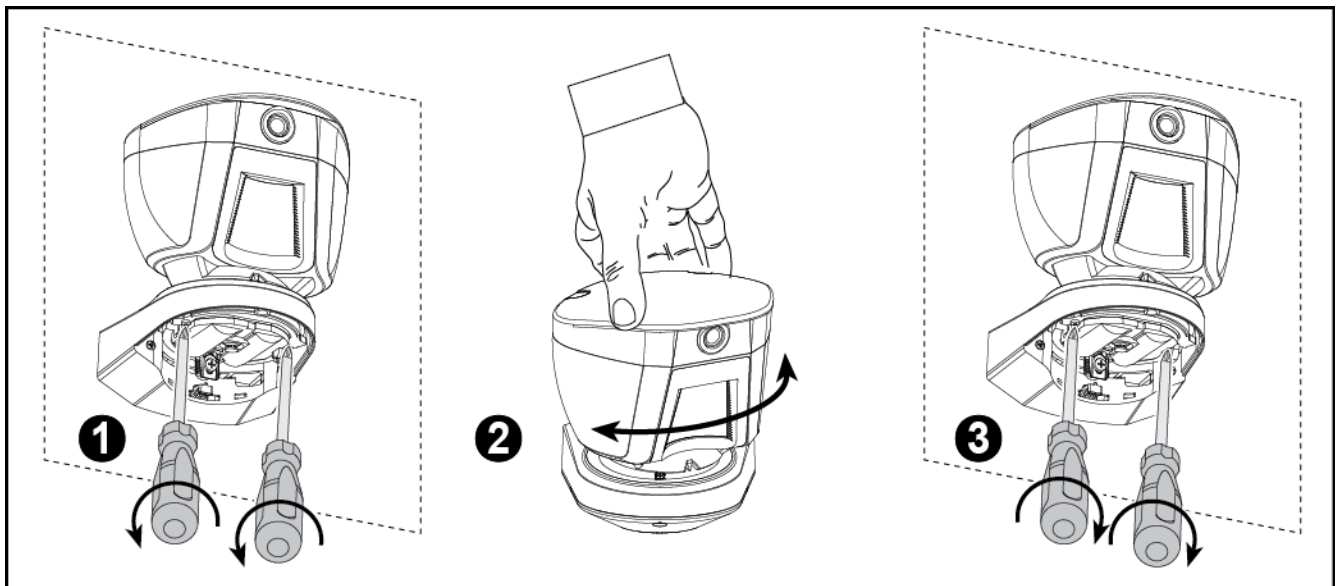

**1**                      **2**                      **3**

**VERTICAL ADJUSTMENT (0° to -10° in 2.5° clicks / steps)**

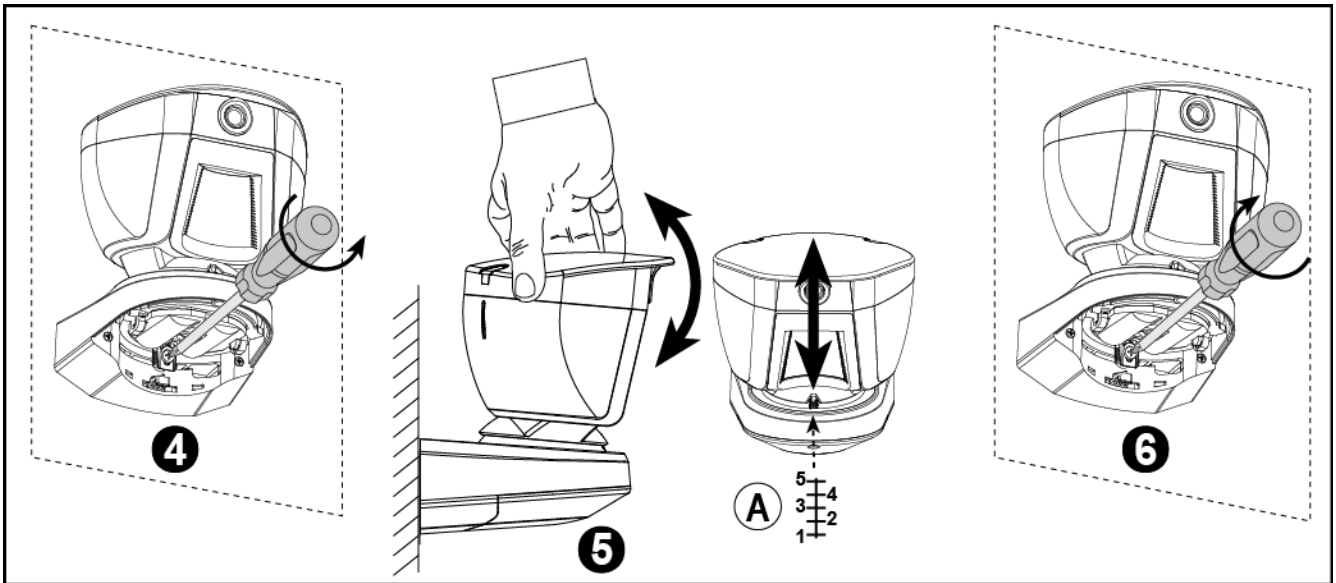

**Installation Notes:**

The top cover should only be accessed by authorized service personnel or manufacturer. Do not obscure the detector field of view with large objects. Install in position such that expected intruder motion is perpendicular to the zones of detection. Alarms triggered by conditions such as weather, blowing leaves and brush, or related environmental conditions, etc., need to be considered when assessing the installation and application. It is recommended that the intrusion detection unit is not to be connected to an alarm initiating circuit but may be connected to a trouble alarm circuit if nuisance trips are not tolerable.

**COVER CLOSURE**

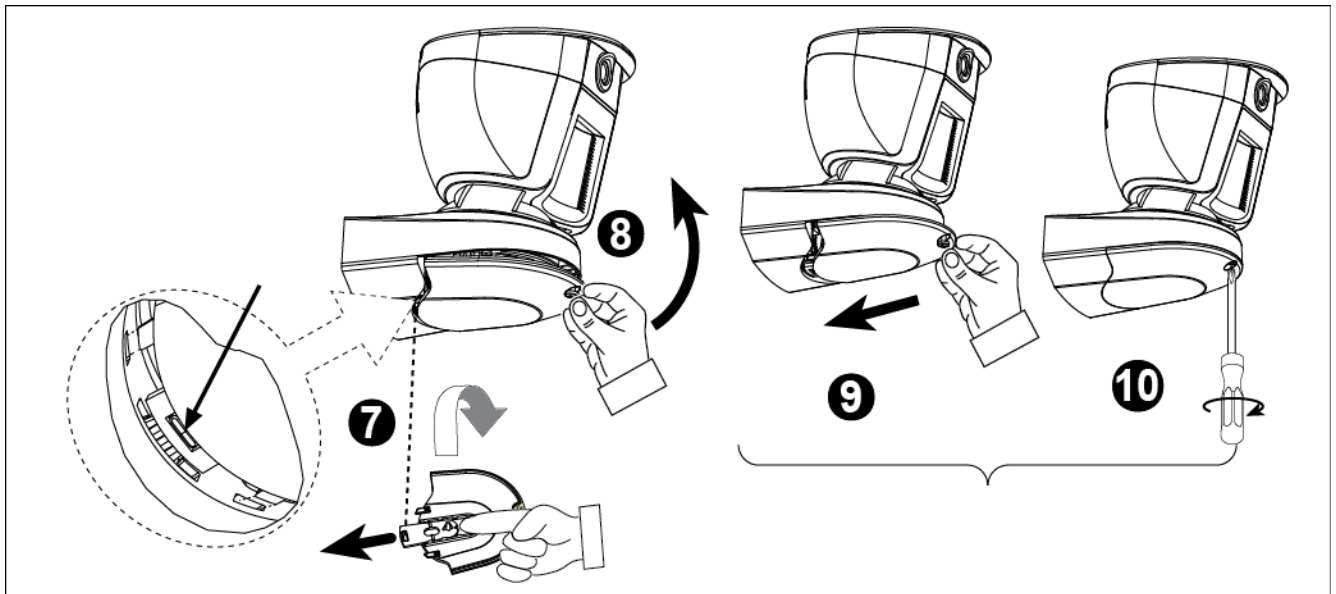

- 1. Release locking
  - 2. Adjust
  - 3. Lock
  - 4. Release locking
  - 5. Adjust
  - 6. Lock
  - 7. Turn cover and push slider
  - 8 & 9. Put back cover
  - 10. Secure with screw
- A. Vertical angle steps

**Figure 3 - Adjustment and Cover Closure**

**2.2. Battery Insertion**

It is recommended to perform the first batteries insertion on a flat surface (see [Figure 4](#)). After battery insertion, the LED will flash for 60 seconds and then the detector will enter a 15 minutes' local diagnostic mode.

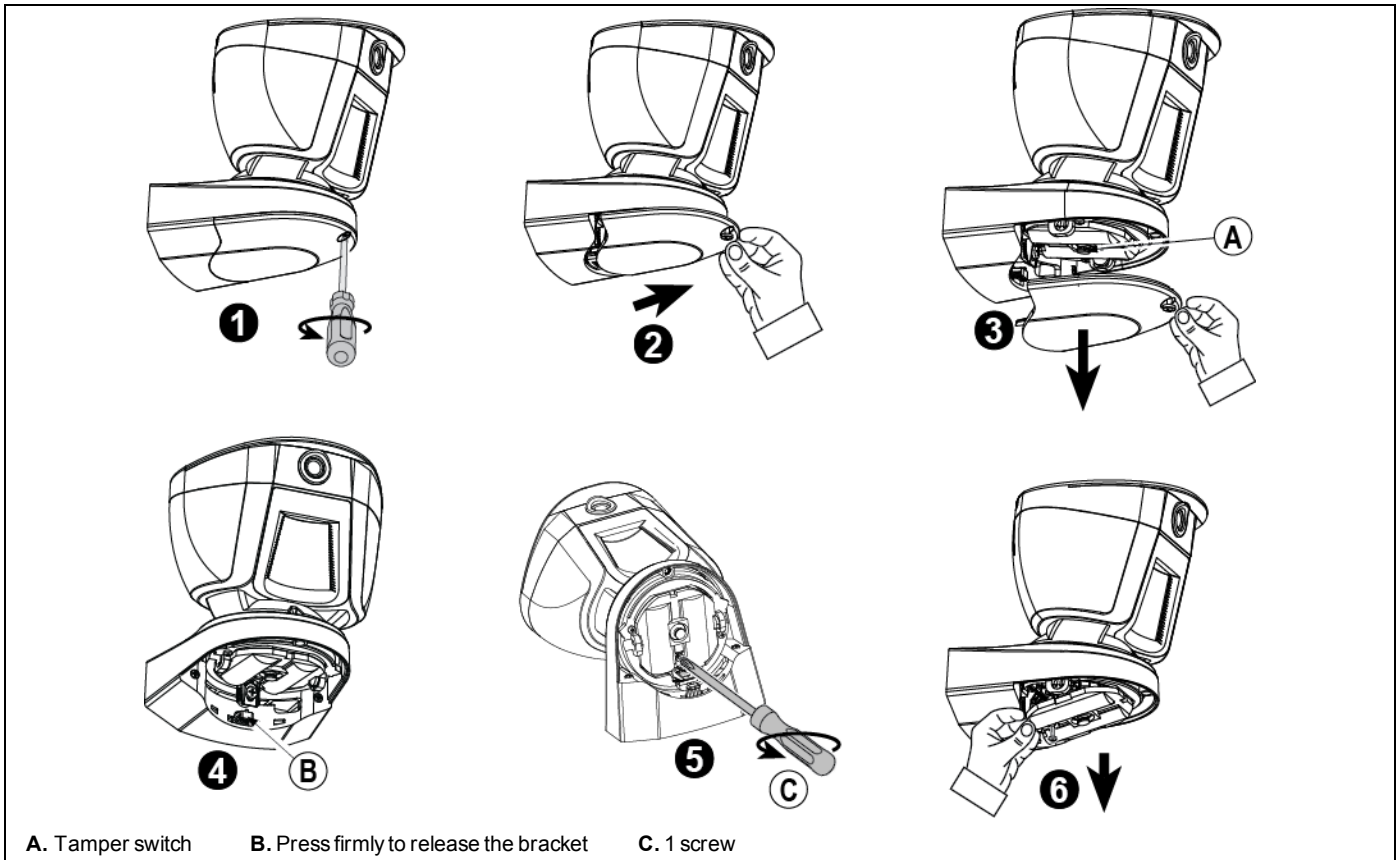

**Steps 7 and 8 are optional for external 7.5 VDC power connection**

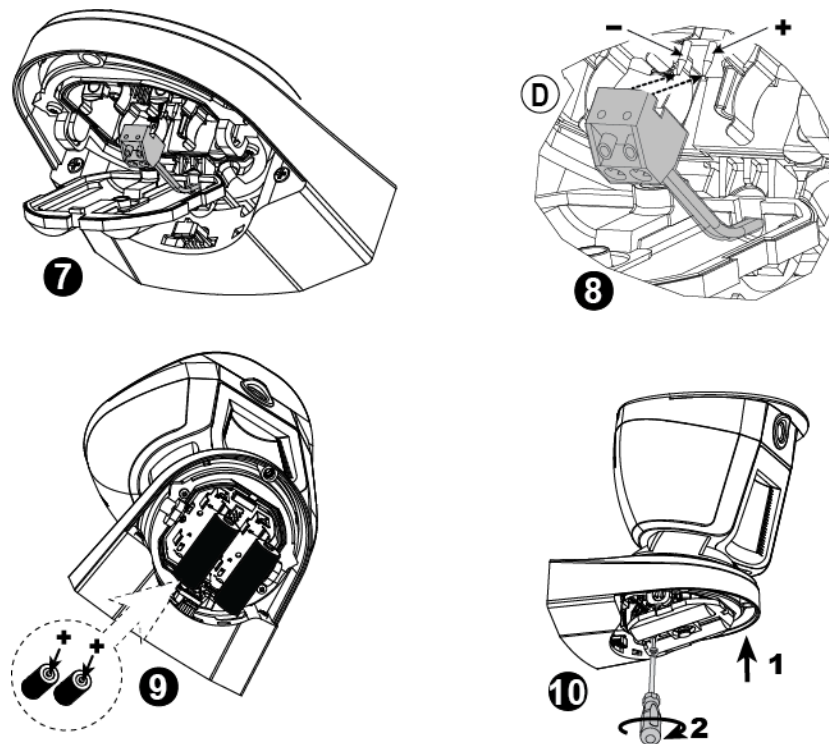

D. Snap the terminal block into place.

**Caution!** Risk of explosion if battery is replaced by an incorrect type. Dispose of used battery according to the manufacturer's instructions.  
**Caution!** The battery used in this device may present a risk of fire or chemical burn if mistreated. Do not disassemble, heat above 66°C, or incinerate. Replace battery with CR17450 Lithium batteries manufactured by EVE only. Dispose of used battery promptly. Keep away from children. Do not disassemble and do not dispose of in fire.

**Note:** Tamper protection is mandatory for UL burglary installations.

**Figure 4 – Battery Insertion**

## 2.3. Enrollment

Refer to the PowerMaster control panel's Installer Guide and follow the procedure under the "02:ZONES/DEVICES" option of the Installer Menu. A general description of the procedure is provided in the following flow chart.

Step 1	Step 2	Step 3	Step 4
Enter the Installer menu and select "02:ZONES/DEVICES"	Select "ADD NEW DEVICE" See Note 1	Enroll the device (see Figure 5) or enter the device ID	Select a detector number for the new detector
02:ZONES/DEVICES ⇨	ADD NEW DEVICES ↓ MODIFY DEVICES	⇨ ENROLL NOW or ENTR ID:XXX-XXXX	⇨ Z09:Motion Camera ID No. 142-XXXX ⇨
Step 5	Step 6	Step 7	
Configure Location, Zone Type & Chime parameters	Enter PARTITIONS. See Note 2	Assign partitions to the detector by pressing the <b>1</b> , <b>2</b> and/or <b>3</b> buttons on the panel	
Z09.LOCATION Z09.ZONE TYPE Z09.SET CHIME	⇨ Z09/PARTITIONS	⇨ Z09:P1■-- P2 ...P3■	⇨

⇨ means scroll ▷▷ and select OK.

### Notes:

- [1] If the detector is already enrolled you can configure the detector parameters and assign partitions via the "Modify Devices" option – see Step 2.  
 [2] PARTITIONS will appear only if PARTITIONING was previously enabled in a panel that supports the Partitioning feature (for further details, see "Partitioning" in the PowerMaster Installer Guide).

## 2.4. Configuring the Detector Parameters

Enter the **DEVICE SETTINGS** menu and follow the configuration instructions for the TOWER CAM PG2 PIR detector as described below.

Option	Configuration Instructions
<b>ALARM LED</b>	Define whether or not to activate the alarm LED indication. Optional settings: ON (default) and OFF.
<b>PIR SENSITIVITY</b>	Define if the detector operates at regular or high PIR sensitivity, or that at least one detection zone must be crossed before an alarm is triggered (One Region). Optional settings: LOW (default), HIGH and One Region. <b>Note:</b> For EN and UL compliance, the detector should be set to "One Region".
<b>DISARM ACTIVITY</b>	Define whether or not to set the activity time during Disarm mode. Optional settings: NOT Active (default), YES – no delay, YES + 5s delay, YES + 15s delay, YES + 30s delay, YES + 1m delay, YES + 2m delay, YES + 5m delay, YES + 10m delay, YES + 20m delay and YES + 60m delay.
<b>OUTDOOR ANTI-M</b>	Enable or disable the outdoor anti-masking feature. Optional settings: Disabled (default) and Enabled.
<b>ALARM Hours</b>	Define whether motion alarms are always enabled or only when dark (at night). Optional settings: Day and Night (default) and Night only. <b>Note:</b> For UL/ULC installation, the Alarm Hours feature when enabled for night protection should only be used as supplemental protection to the protection covering the protected area.
<b>IMAGE COLOR</b>	Define whether the image will be in black & white or color. Optional settings: Black & White (default) and Color.
<b>IMAGE RESOLUTION</b>	Set the pixel quality of the image. Select 160 x 120 for lower quality or 320 x 240 for higher quality. Optional settings: 320 x 240 (default) and 160 x 120.
<b>IMAGE QUALITY</b>	Set the quality of the image. Optional settings: High (default) and normal.
<b>IMAGE BRIGHTNESS</b>	Set the brightness of the image. Optional settings: Normal (default) -3, -2, -1, +1, +2 and +3.
<b>IMAGE CONTRAST</b>	Set the contrast of the image. Optional settings: Normal (default) -3, -2, -1, +1, +2 and +3.

## 2.5. Local Diagnostic Test

- A. Set the detector in local diagnostic mode, as follows:  
Open the detector's bottom cover (see [Figure 4](#), steps 1 - 3) and then press and release the tamper switch (see [Figure 5](#)). The LED will flash for 60 seconds and then the detector will enter into 15 minutes' local diagnostic mode.  
**Note:** *The detector automatically enters into 15 minutes' local diagnostic mode after battery installation or Tamper switch recovery.*
- B. Adjust the detector in the horizontal plane to cover the required protected area.
- C. Walk into the detectors' field of view. Adjust the vertical plane to receive the maximum number of detections when crossing the entire 90° pattern. Verify that the LED blinks each time your motion is detected, as you cross one Quad PIR. Then verify that the LED lights steadily for 2 seconds as you cross the next adjacent Quad PIR. After alarm indication, the LED blinks three times and provides the received signal strength indication (see [Table 2](#)).

**Table 2 – Received Signal Strength Indication**

LED response	Reception
Green LED blinks	Strong
Orange LED blinks	Good
Red LED blinks	Poor
No blinks	No communication

**Important!** *Reliable reception must be assured. Therefore, "poor" signal strength is not acceptable. If you receive a "poor" signal from the detector, re-locate it and re-test until a "Good" or "Strong" signal strength is received.*

**Note:** *For detailed Diagnostics Test instructions refer to the control panel Installer's Guide.*

*The LED blinking, described above, is operative only in Local diagnostic mode. Upon each full detection (LED lights steadily for 2 seconds), the control panel receives the alarm. If required, perform the detector's horizontal / vertical adjustments (see section 2.1 and [Figure 3](#)).*

**Important!** *Instruct the user to perform a walk test at least once a week, to verify proper operation of the detector.*

- D. Place a piece of cardboard on the detector's front side to deliberately mask the optical window. Verify that after 2 minutes, the yellow LED lights continuously (see [Table 3](#) below) and the alarm control panel receives the masking alarm.
- E. Remove the masking from the detector's front side. Verify that the LED turns off after 30 seconds.

**Table 3 - LED operation**

LED Indications	Event
Red Alarm LED blinks	Stabilization (warm-up 60 sec)
Red Alarm LED ON 0.2 sec.	Tamper open / close
Red Alarm LED blinks twice	One quad PIR detection in diagnostic mode
Red Alarm LED on 2 sec.	Intruder alarm
Yellow Indication LED on	AM detection – diagnostic mode
Yellow indication LED blinks slowly (0.2 sec. ON, 30 sec. OFF)	AM detection – Normal mode

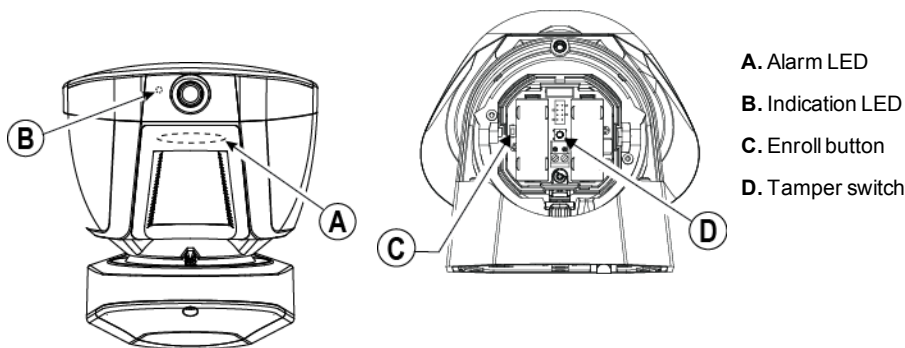

**Figure 5. TOWER CAM PG2**

# 1. COMPLIANCE WITH STANDARDS

## Compliance with Standards



The TOWER CAM PG2 is designed to comply with the following standards:

**Europe (CE):** EN 300220, EN 301489, EN 60950, EN 50130-4, EN 50130-5, EN 50131-2-2, EN 50131-6, EN 50131-1 Grade 2 Class IV

The TOWER CAM PG2 is compatible with the RTTE requirements - Directive 1999/5/EC of the European Parliament and of the Council of 9 March 1999 and EN50131-1 Grade 2 Class IV.

**UK:** This product is suitable for use in systems installed to conform to PD6662:2010 at Grade 2 and environmental class 4. DD243 and BS8243

Certified by Norwegian accredited certification body Aplica Test & Certification AS in accordance with EN 50131-2-2

**USA:** CFR 47 Part 15 (FCC), UL-639

**Canada:** RSS 210 (IC), ULC S306

*The Power G peripheral devices have two-way communication functionality, providing additional benefits as described in the technical brochure. This functionality has not been tested to comply with the respective technical requirements and should therefore be considered outside the scope of the product's certification.*



**EN 50131-1 Security Grade**

Grade 2

**EN 50131-1 Environmental Class**

Class IV

## FCC Compliance Statement

This device has been tested and found to comply with the limits for a Class B digital device, pursuant to Part 15 of the FCC Rules. These limits are designed to provide reasonable protection against harmful interference in residential installations. This equipment generates uses and can radiate radio frequency energy and, if not installed and used in accordance with the instructions, may cause harmful interference to radio and television reception.

However, there is no guarantee that interference will not occur in a particular installation. If this device does cause such interference, which can be verified by turning the device off and on, the user is encouraged to eliminate the interference by one or more of the following measures:

- Re-orient or re-locate the receiving antenna.
- Increase the distance between the device and the receiver.
- Connect the device to an outlet on a circuit different from the one that supplies power to the receiver.
- Consult the dealer or an experienced radio/TV technician.

**Warning!** Changes or modifications to this unit not expressly approved by the party responsible for compliance could void the user's authority to operate the equipment.

This device complies with FCC Rules Part 15 and with Industry Canada licence-exempt RSS standard (s). Operation is subject to two conditions: (1) This device may not cause harmful interference and (2) this device must accept any interference that may be received or that may cause undesired operation.

Le present appareil est conforme aux CNR d'Industrie Canada applicables aux appareils radio exempts de licence. L'exploitation est autorisee aux deux conditions suivantes : (1) l'appareil ne doit pas produire de brouillage et (2) l'utilisateur de l'appareil doit accepter tout brouillage radioelectrique subi, meme si le brouillage est susceptible d'en compromettre le fonctionnement.



### W.E.E.E. Product Recycling Declaration

For information regarding the recycling of this product you must contact the company from which you originally purchased it. If you are discarding this product and not returning it for repair then you must ensure that it is returned as identified by your supplier. This product is not to be thrown away with everyday waste.  
Directive 2002/96/EC Waste Electrical and Electronic Equipment.

## APPENDIX: SPECIFICATIONS

### OPTICAL

**Black Mirror Max. Coverage**

Up to 12 m (40 ft) / 90°

**Detector Technology**

8 independent quad PIR detectors operating in true Quad configuration

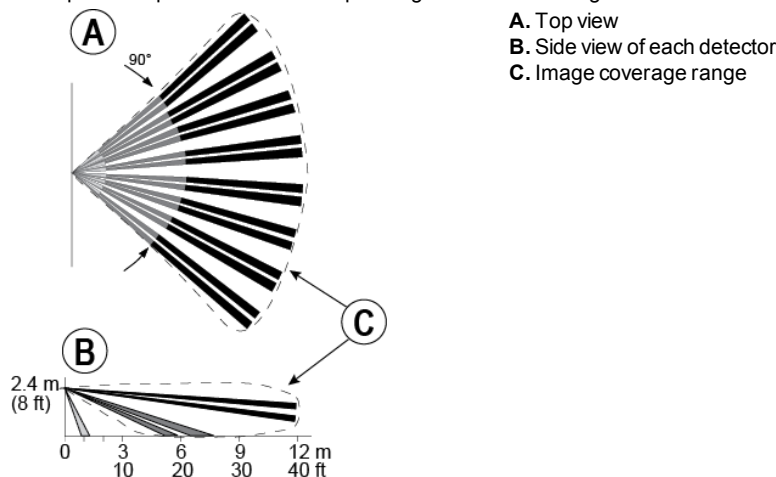

Figure 6. Coverage Pattern

**Pet Immunity**

Up to 18 Kg (40 lb)

## ELECTRICAL

Input Power	Two 3V / 2400 mAh, CR17450 Lithium batteries manufactured by EVE.
Battery Life (for typical use)	3 years <b>Note:</b> Minimum one year, typical 3 years (not verified by UL/ULC)
Low Battery Threshold	4.0 V
Optional Mains Supply	Additional to batteries, 7.5 V DC, 1.5 A <b>Note:</b> For UL/ULC installation, the 7.5 VDC power connection was not evaluated by UL.

## FUNCTIONAL

IR Illumination	10 m (33 ft)
Picture Resolution	320x240 pixels QVGA or 160X120 pixels QQVGA
Frame Rate	2 fps

## WIRELESS

Frequency Band (MHz)	<b>Europe and rest of world:</b> 433-434, 868-869 <b>USA:</b> 912-919 <b>Note:</b> Only devices operating in band 912-919 MHz are UL/ULC listed.
Communication Protocol	PowerG
Tamper Alert	Reported when a tamper event occurs and in any subsequent message, until the tamper switch is restored

## MOUNTING

Mounting Type	Wall mounting
Mounting Height	1.5 – 3.0 m (5 – 10 ft).
Horizontal Adjustment	-45° to +45°, in 5° steps
Vertical Adjustment	0° to -10°, in 2.5° steps

## ENVIRONMENTAL

Operating Temperatures	-35°C to 60°C (-31°F to 140°F) <b>Note:</b> For UL/ULC installation, evaluated to 66°C
Storage Temperatures	-35°C to 60°C (-31°F to 140°F)
Humidity	93% max.
White Light Immunity	Above 25000 lux

## PHYSICAL

Size (H x L x W)	166 x 147 x 124 mm (6-9/16 x 5-13/16 x 4-7/8")
Weight (with battery)	700 g (25 oz).
Color	White
PATENTS	U.S. Patents 7250605 • 6818881 • 5693943 (other patents pending)

## WARRANTY

Visonic Limited (the "Manufacturer") warrants this product only (the "Product") to the original purchaser only (the "Purchaser") against defective workmanship and materials under normal use of the Product for a period of twelve (12) months from the date of shipment by the Manufacturer.

This Warranty is absolutely conditional upon the Product having been properly installed, maintained and operated under conditions of normal use in accordance with the Manufacturer's recommended installation and operation instructions. Products which have become defective for any other reason, according to the Manufacturer's discretion, such as improper installation, failure to follow recommended installation and operational instructions, neglect, willful damage, misuse or vandalism, accidental damage, alteration or tampering, or repair by anyone other than the manufacturer, are not covered by this Warranty.

The Manufacturer does not represent that this Product may not be compromised and/or circumvented or that the Product will prevent any death and/or personal injury and/or damage to property resulting from burglary, robbery, fire or otherwise, or that the Product will in all cases provide adequate warning or protection. The Product, properly installed and maintained, only reduces the risk of such events without warning and it is not a guarantee or insurance that such events will not occur.

**THIS WARRANTY IS EXCLUSIVE AND EXPRESSLY IN LIEU OF ALL OTHER WARRANTIES, OBLIGATIONS OR LIABILITIES, WHETHER WRITTEN, ORAL, EXPRESS OR IMPLIED, INCLUDING ANY WARRANTY OF MERCHANTABILITY OR FITNESS FOR A PARTICULAR PURPOSE, OR OTHERWISE. IN NO CASE SHALL THE MANUFACTURER BE LIABLE TO ANYONE FOR ANY CONSEQUENTIAL OR INCIDENTAL DAMAGES FOR BREACH OF THIS WARRANTY OR ANY OTHER WARRANTIES WHATSOEVER, AS AFORESAID.**

**THE MANUFACTURER SHALL IN NO EVENT BE LIABLE FOR ANY SPECIAL, INDIRECT, INCIDENTAL, CONSEQUENTIAL OR PUNITIVE DAMAGES OR FOR LOSS, DAMAGE, OR EXPENSE, INCLUDING LOSS OF USE, PROFITS, REVENUE, OR GOODWILL, DIRECTLY OR INDIRECTLY ARISING FROM PURCHASER'S USE OR INABILITY TO USE THE PRODUCT, OR FOR LOSS OR DESTRUCTION OF OTHER PROPERTY OR FROM ANY OTHER CAUSE, EVEN IF MANUFACTURER HAS BEEN ADVISED OF THE POSSIBILITY OF SUCH DAMAGE.**

**THE MANUFACTURER SHALL HAVE NO LIABILITY FOR ANY DEATH, PERSONAL AND/OR BODILY INJURY AND/OR DAMAGE TO PROPERTY OR OTHER LOSS WHETHER DIRECT, INDIRECT, INCIDENTAL, CONSEQUENTIAL OR OTHERWISE, BASED ON A CLAIM THAT THE PRODUCT FAILED TO FUNCTION.**

However, if the Manufacturer is held liable, whether directly or indirectly, for any loss or damage arising under this limited warranty, **THE MANUFACTURER'S MAXIMUM LIABILITY (IF ANY) SHALL NOT IN ANY CASE EXCEED THE PURCHASE PRICE OF THE PRODUCT**, which shall be fixed as liquidated damages and not as a penalty, and shall be the complete and exclusive remedy against the Manufacturer.

When accepting the delivery of the Product, the Purchaser agrees to the said conditions of sale and warranty and he recognizes having been informed of.

Some jurisdictions do not allow the exclusion or limitation of incidental or consequential damages, so these limitations may not apply under certain circumstances.

The Manufacturer shall be under no liability whatsoever arising out of the corruption and/or malfunctioning of any telecommunication or electronic equipment or any programs.

The Manufacturer's obligations under this Warranty are limited solely to repair and/or replace at the Manufacturer's discretion any Product or part thereof that may prove defective. Any repair and/or replacement shall not extend the original Warranty period. The Manufacturer shall not be responsible for dismantling and/or reinstallation costs. To exercise this Warranty the Product must be returned to the Manufacturer freight pre-paid and insured. All freight and insurance costs are the responsibility of the Purchaser and are not included in this Warranty.

This warranty shall not be modified, varied or extended, and the Manufacturer does not authorize any person to act on its behalf in the modification, variation or extension of this warranty. This warranty shall apply to the Product only. All products, accessories or attachments of others used in conjunction with the Product, including batteries, shall be covered solely by their own warranty, if any. The Manufacturer shall not be liable for any damage or loss whatsoever, whether directly, indirectly, incidentally, consequentially or otherwise, caused by the malfunction of the Product due to products, accessories, or attachments of others, including batteries, used in conjunction with the Products. This Warranty is exclusive to the original Purchaser and is not assignable.

This Warranty is in addition to and does not affect your legal rights. Any provision in this warranty which is contrary to the Law in the state or country where the Product is supplied shall not apply.

**Warning:** The user must follow the Manufacturer's installation and operational instructions including testing the Product and its whole system at least once a week and to take all necessary precautions for his/her safety and the protection of his/her property.

1/08



EMAIL: info@visonic.com  
INTERNET: www.visonic.com  
© VISONIC LTD. 2016 TOWER CAM PG2 D-304493 (Rev. 5 04/16)

