

MCS-720B

Fully Wireless Indoor Siren



Installation Instructions

1. INTRODUCTION

The MCS-720B is a fully supervised wireless siren, for indoor use, that communicates with PowerMax Pro or PowerMaxComplete alarm system.

Features

- The siren is activated according to specific commands that are transmitted from the alarm system (refer to the alarm system specifications - SIREN SIGNALS).
 - Note:** The siren is activated for a predefined "Bell Time" (refer to PowerMax Pro / PowerMaxComplete installer guide, par. 4.4), according to local authorities requirements, or until the system is disarmed, whichever occurs first.
- **Squawk indications when using a keyfob**
High, mid or low siren squawk (beep) sound can be used to indicate arming (1 squawk) and disarming (2 squawks) of the alarm system.
- **Flash lights / strobe**
When an identified activation command is received from the alarm system, the strobe light is activated every 1 second (100ms ON, 900ms OFF) for a period of 20 minutes maximum, or until the alarm system is disarmed whichever occurs first. There is an option to disable the lights/strobe locally by using an internal jumper.
- **Tamper protection**
The unit has tamper protection for wall and front cover opening alarm.
- **Low battery voltage alert**
When the battery voltage is low, low battery message is sent to the alarm system. After the low voltage message delivery, at least 2 siren alarms are possible before the siren is totally inactive.
- **2-way full supervision**
The siren is a fully supervised, 2-way communication device. It includes a receiver, to receive activation commands from the alarm system, and a transmitter, to periodically transmit its status signal to the alarm system.

The transmitted signal strength can be measured during the installation (refer to the PowerMax Pro / PowerMaxComplete Installer Guide, paragraph 5.2 – Diagnostic Test).

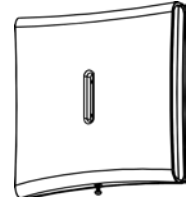

Figure 1 - MCS-720B

• Self-test feature

The siren can be tested locally (by using the SELF-TEST switch) or remotely (from the control panel), upon batteries insertion, prior to the actual wall installation.

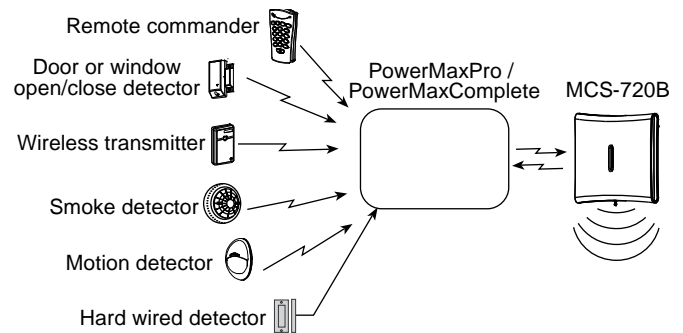

Figure 2 - Integration with the Alarm System.

2. SPECIFICATIONS

- Siren Type:** At least 85 dBA at 10 ft (3 m), 1.8-3.5 kHz, sweep frequency 7Hz.
- Battery:** Four 3.6V/3.5A/H Lithium independent cells (EVE ER18505M) assembled in two plastic wrappings and connected to the cable adaptor (see Figure 4). Visonic assembly catalog no. 103-304742.
- Battery life expectancy:** 3 years (for typical use)
- Low Battery Threshold:** 2 V +300 mV negative slope OR 1.2 V
- Quiescent Current Consumption:** 58 µA
- Peak Current Consumption:** 500 mA
- Operating Frequency (MHz):** 315, 433.92, 868.95, or other frequency according to the requirement in the country of use.
- Receiver and Transmitter ID Type:** 24-bit
- Flash Lights Duration:** 100ms ON, 900ms OFF

- Dimensions (LxWxD):** 161x161x50mm (6-7/16 x 6-7/16 x 1-3/4 in)
- Weight (with battery):** 470g (16.5 oz.)
- Color:** White
- Operating Temperature:** -10°C to 60°C (-14°F to 140°F)
- Compliance with Standards:**
 - Europe :** EN 50130-4, EN 50130-5, EN 50131-4 Type W. Security Grade 2, Class II
 - USA:** (FCC) CFR 47part 15, IC: RSS 210
- Certified by Applicia T&C.*

The MCS-720B is compatible with the RTTE requirements - Directive 1999/5/EC of the European Parliament and of the Council of 9 March 1999.

3. INSTALLATION, TESTING AND ENROLLING

3.1 Installation

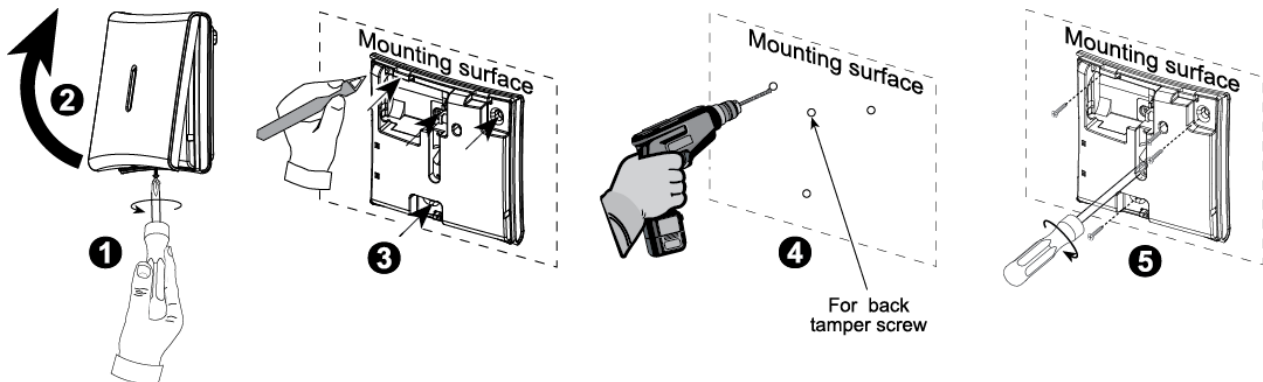

Figure 3 - Installation

3.2 Battery Pack Insertion

Note: Battery replacement should be done by a service engineer.
Caution! Risk of explosion if battery is replaced by an incorrect type.
 Dispose of used battery according to the manufacturer's instructions.

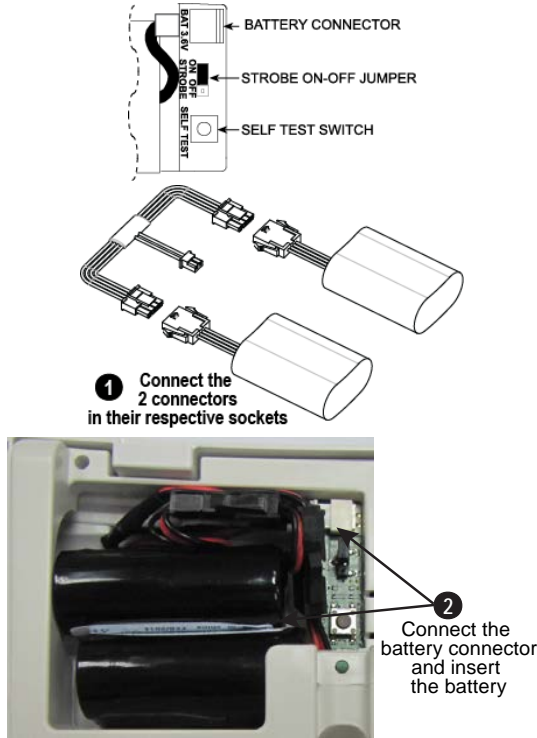

Figure 4 - Battery Pack Insertion

3.3 Self-Test

Upon pressing the self-test switch more than 3 seconds (see Fig. 4), the siren performs a functionality check during which low level piezo sounds and flash lights indicate that the siren is fully operational.

3.4 Enrolling

The PowerMax Pro / PowerMaxComplete alarm system must recognize the siren's unique identification code for command delivery and supervision. To enroll the siren into the alarm system memory, refer to the ENROLLING section of the control panel installation instructions, and momentarily press the self-test switch (see figure 4) when you are instructed.

After the enrolling, close the siren's cover and perform diagnostic test, as described in PowerMax Pro / PowerMaxComplete installer guide, DIAGNOSTIC section. Enrolling cancellation, if required, is also described in the control panel Installer Guide (see the ENROLLING section).

Note

To remove the siren or to replace its battery, without activating the siren, login the alarm system Installer Mode and delete the siren from the alarm system control panel memory, before siren removal or siren battery replacement.

3.5 Strobe Light Enabling / Disabling

Enable or disable the strobe (flash) light by using the STROBE ON-OFF jumper (see figure 4).

3.6 Cover Closure

See Figure 5.

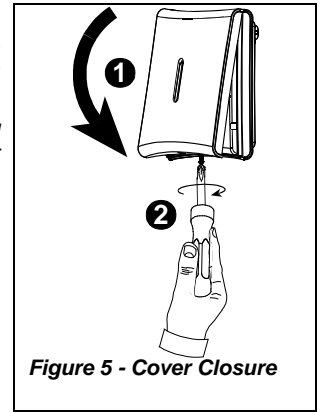

Figure 5 - Cover Closure

Interference Prevention

This device complies with FCC Rules Part 15. Operation is subject to two conditions: (1) This device may not cause harmful interference, and (2) this device must accept any interference that may be received or that may cause undesired operation.

This device complies with Industry Canada's license-exempt RSSs. Operation is subject to the following two conditions:

- (1) This device may not cause interference; and
- (2) This device must accept any interference, including interference that may cause undesired operation of the device.

Le present appareil est conforme aux CNR d'Industrie Canada applicables aux appareils radio exempts de licence. L'exploitation est autorisee aux deux conditions suivantes : (1) l'appareil ne doit pas produire de brouillage, et (2) l'utilisateur de l'appareil doit accepter tout brouillage radioelectrique subi, meme si le brouillage est susceptible d'en compromettre le fonctionnement.

The digital circuit of this device has been tested and found to comply with the limits for a Class B digital device, pursuant to Part 15 of the FCC Rules. These limits are designed to provide reasonable protection against harmful interference in residential installations. This equipment generates, uses and can radiate radio frequency energy and, if not installed and used in accordance with the instructions, may cause harmful interference to radio and television reception. However, there is no guarantee that interference will not occur in a particular installation. If this device does cause such interference, which can be verified by turning the device off and on, the user is encouraged to eliminate the interference by one or more of the following measures:

- Re-orient or re-locate the receiving antenna.
 - Increase the distance between the device and the receiver.
 - Connect the device to an outlet on a circuit different from the one which supplies power to the receiver.
 - Consult the dealer or an experienced radio/TV technician.
- Changes or modifications not expressly approved by Visonic Ltd. could void the user's authority to operate the equipment.

WARRANTY

Visonic Limited (the "Manufacturer") warrants this product only (the "Product") to the original purchaser only (the "Purchaser") against defective workmanship and materials under normal use of the Product for a period of twelve (12) months from the date of shipment by the Manufacturer.

This Warranty is absolutely conditional upon the Product having been properly installed, maintained and operated under conditions of normal use in accordance with the Manufacturer's recommended installation and operation instructions. Products which have become defective for any other reason, according to the Manufacturer's discretion, such as improper installation, failure to follow recommended installation and operational instructions, neglect, willful damage, misuse or vandalism, accidental damage, alteration or tampering, or repair by anyone other than the manufacturer, are not covered by this Warranty.

The Manufacturer does not represent that this Product may not be compromised and/or circumvented or that the Product will prevent any death and/or personal injury and/or damage to property resulting from burglary, robbery, fire or otherwise, or that the Product will in all cases provide adequate warning or protection. The Product, properly installed and maintained, only reduces the risk of such events without warning and it is not a guarantee or insurance that such events will not occur.

THIS WARRANTY IS EXCLUSIVE AND EXPRESSLY IN LIEU OF ALL OTHER WARRANTIES, OBLIGATIONS OR LIABILITIES, WHETHER WRITTEN, ORAL, EXPRESS OR IMPLIED, INCLUDING ANY WARRANTY OF MERCHANTABILITY OR FITNESS FOR A PARTICULAR PURPOSE, OR OTHERWISE. IN NO CASE SHALL THE MANUFACTURER BE LIABLE TO ANYONE FOR ANY CONSEQUENTIAL OR INCIDENTAL DAMAGES FOR BREACH OF THIS WARRANTY OR ANY OTHER WARRANTIES WHATSOEVER, AS AFORESAID.

THE MANUFACTURER SHALL IN NO EVENT BE LIABLE FOR ANY SPECIAL, INDIRECT, INCIDENTAL, CONSEQUENTIAL OR PUNITIVE DAMAGES OR FOR LOSS, DAMAGE, OR EXPENSE, INCLUDING LOSS OF USE, PROFITS, REVENUE, OR GOODWILL, DIRECTLY OR INDIRECTLY ARISING FROM PURCHASER'S USE OR INABILITY TO USE THE PRODUCT, OR FOR LOSS OR DESTRUCTION OF OTHER PROPERTY OR FROM ANY OTHER CAUSE, EVEN IF MANUFACTURER HAS BEEN ADVISED OF THE POSSIBILITY OF SUCH DAMAGE.

THE MANUFACTURER SHALL HAVE NO LIABILITY FOR ANY DEATH, PERSONAL AND/OR BODILY INJURY AND/OR DAMAGE TO PROPERTY OR OTHER LOSS WHETHER DIRECT, INDIRECT, INCIDENTAL, CONSEQUENTIAL OR OTHERWISE, BASED ON A CLAIM THAT THE PRODUCT FAILED TO FUNCTION.

However, if the Manufacturer is held liable, whether directly or indirectly, for any loss or damage arising under this limited warranty, the Manufacturer's maximum liability (if any) shall not in any case exceed the purchase price of the Product, which shall be fixed as liquidated damages and not as a penalty, and shall be the complete and exclusive remedy against the Manufacturer.

When accepting the delivery of the Product, the Purchaser agrees to the said conditions of sale and warranty and he recognizes having been informed of.

Some jurisdictions do not allow the exclusion or limitation of incidental or consequential damages, so these limitations may not apply under certain circumstances.

The Manufacturer shall be under no liability whatsoever arising out of the corruption and/or malfunctioning of any telecommunication or electronic equipment or any programs.

The Manufacturer's obligations under this Warranty are limited solely to repair and/or replace at the Manufacturer's discretion any Product or part thereof that may prove defective. Any repair and/or replacement shall not extend the original Warranty period. The Manufacturer shall not be responsible for dismantling and/or reinstallation costs. To exercise this Warranty the Product must be returned to the Manufacturer freight pre-paid and insured. All freight and insurance costs are the responsibility of the Purchaser and are not included in this Warranty.

This Warranty shall not be modified, varied or extended, and the Manufacturer does not authorize any person to act on its behalf in the modification, variation or extension of this warranty. This warranty shall apply to the Product only. All products, accessories or attachments of others used in conjunction with the Product, including batteries, shall be covered solely by their own warranty, if any. The Manufacturer shall not be liable for any damage or loss whatsoever, whether directly, indirectly, incidentally, consequentially or otherwise, caused by the malfunction of the Product due to products, accessories, or attachments of others, including batteries, used in conjunction with the Products. This Warranty is exclusive to the original Purchaser and is not assignable.

This Warranty is in addition to and does not affect your legal rights. Any provision in this warranty which is contrary to the Law in the state or country where the Product is supplied shall not apply.

Warning: The user must follow the Manufacturer's installation and operational instructions including testing the Product and its whole system at least once a week and to take all necessary precautions for his/her safety and the protection of his/her property.

1/08



W.E.E. Product Recycling Declaration

For information regarding the recycling of this product you must contact the company from which you originally purchased it. If you are discarding this product and not returning it for repair then you must ensure that it is returned as identified by your supplier. This product is not to be thrown away with everyday waste.

Directive 2002/96/EC Waste Electrical and Electronic Equipment.



EMAIL: info@visonic.com
 INTERNET: www.visonic.com
 ©VISONIC LTD. 2016 MCS-720B, D-305643 Rev 1 (03/16)



D-305643

